

Zener Diodes

VOLTAGE - 2.2 to 100 Volts

POWER - 500 mWatts

FEATURES

- Planar Die Construction
- 500mW Power Dissipation
- Ideally Suited for Automated Assembly Processes
- In Compliance With EU RoHS 2002/95/EC Directives

MECHANICAL DATA

- Case: Molded Glass MINI-MELF
- Terminals: Solderable per MIL-STD-750, Method 2026
- Polarity: See Diagram Below
- Approx. Weight: 0.03 grams
- Mounting Position: Any
- Packing Information

T/R-2.5K per 7" plastic Reel

T/R-10K per 13" plastic Reel

DL-35

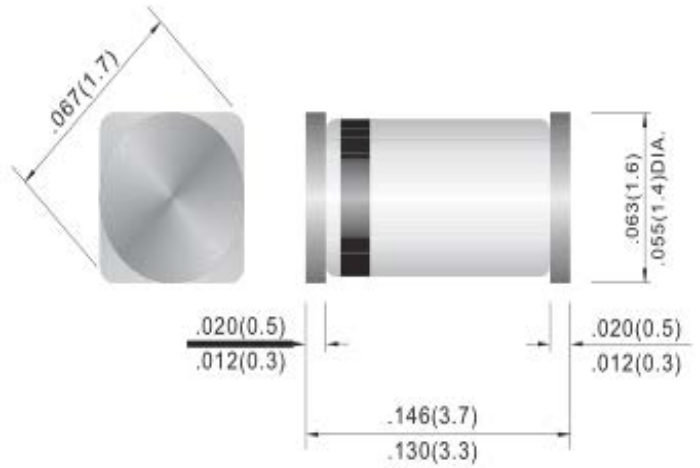

Unit :inch(mm)

MAXIMUM RATINGS AND ELECTRICAL CHARACTERISTICS

Parameter	Symbol	Value	Units
Power Dissipation at Tamb = 25°C	P _{TOT}	500	mW
Junction Temperature	T _J	175	°C
Storage Temperature Range	T _s	-65 to +175	°C

Valid provided that leads at a distance of 8mm from case are kept at ambient temperature.

Parameter	Symbol	Min	Typ	Max	Units
Thermal Resistance Junction to Ambient Air	R _{θJA}	---	---	0.3	K/mW
Forward Voltage at I _F =200mA	V _F	---	---	1.5	V

Valid provided that leads at a distance of 8 mm from case are kept at ambient temperature.

BZV55-C2V2 SERIES



Part Number	Nominal Zener Voltage			Max.Zener Impedance				Max Reverse Leakage Current		marking code
	Vz @ IzT			ZzT @ IzT		Zzk @ Izk		Ir @ VR		
	Nom. V	Min. V	Max. V	Ω	mA	Ω	mA	μA	V	
BZV55-C2V2	2.20	2.09	2.31	85	5.0	600	1.00	50	1.0	C2V2
BZV55-C2V4	2.40	2.28	2.56	85	5.0	600	1.00	50	1.0	C2V4
BZV55-C2V7	2.70	2.50	2.90	85	5.0	600	1.00	10	1.0	C2V7
BZV55-C3V0	3.00	2.80	3.20	85	5.0	600	1.00	4	1.0	C3V0
BZV55-C3V3	3.30	3.10	3.50	85	5.0	600	1.00	2	1.0	C3V3
BZV55-C3V6	3.60	3.40	3.80	85	5.0	600	1.00	2	1.0	C3V6
BZV55-C3V9	3.90	3.70	4.10	85	5.0	600	1.00	2	1.0	C3V9
BZV55-C4V3	4.30	4.00	4.60	75	5.0	600	1.00	1	1.0	C4V3
BZV55-C4V7	4.70	4.40	5.00	60	5.0	600	1.00	0.5	1.0	C4V7
BZV55-C5V1	5.10	4.80	5.40	35	5.0	550	1.00	0.1	1.0	C5V1
BZV55-C5V6	5.60	5.20	6.00	25	5.0	450	1.00	0.1	1.0	C5V6
BZV55-C6V2	6.20	5.80	6.60	10	5.0	200	1.00	0.1	2.0	C6V2
BZV55-C6V8	6.80	6.40	7.20	8	5.0	150	1.00	0.1	3.0	C6V8
BZV55-C7V5	7.50	7.00	7.90	7	5.0	50	1.00	0.1	5.0	C7V5
BZV55-C8V2	8.20	7.70	8.70	7	5.0	50	1.00	0.1	6.0	C8V2
BZV55-C9V1	9.10	8.50	9.60	10	5.0	50	1.00	0.1	7.0	C9V1
BZV55-C10	10.00	9.40	10.60	15	5.0	70	1.00	0.1	7.5	C10V
BZV55-C11	11.00	10.40	11.60	20	5.0	70	1.00	0.1	8.5	C11V
BZV55-C12	12.00	11.40	12.70	20	5.0	90	1.00	0.1	9.0	C12V
BZV55-C13	13.00	12.40	14.10	26	5.0	110	1.00	0.1	10.0	C13V
BZV55-C15	15.00	13.80	15.60	30	5.0	110	1.00	0.1	11.0	C15V
BZV55-C16	16.00	15.30	17.10	40	5.0	170	1.00	0.1	12.0	C16V
BZV55-C18	18.00	16.80	19.10	50	5.0	170	1.00	0.1	14.0	C18V
BZV55-C20	20.00	18.80	21.20	55	5.0	220	1.00	0.1	15.0	C20V
BZV55-C22	22.00	20.80	23.30	55	5.0	220	1.00	0.1	17.0	C22V
BZV55-C24	24.00	22.80	25.60	80	5.0	220	1.00	0.1	18.0	C24V
BZV55-C27	27.00	25.10	28.90	80	5.0	220	1.00	0.1	20.0	C27V
BZV55-C30	30.00	28.00	32.00	80	5.0	220	1.00	0.1	22.0	C30V
BZV55-C33	33.00	31.00	35.00	80	5.0	220	1.00	0.1	24.0	C33V
BZV55-C36	36.00	34.00	38.00	80	5.0	220	1.00	0.1	27.0	C36V
BZV55-C39	39.00	37.00	41.00	90	2.5	500	1.00	0.1	30.0	C39V
BZV55-C43	43.00	40.00	46.00	90	2.5	600	1.00	0.1	33.0	C43V
BZV55-C47	47.00	44.00	50.00	110	2.5	700	1.00	0.1	36.0	C47V
BZV55-C51	51.00	48.00	54.00	125	2.5	700	0.50	0.1	39.0	C51V
BZV55-C56	56.00	52.00	60.00	135	2.5	1000	0.50	0.1	43.0	C56V
BZV55-C62	62.00	58.00	66.00	150	2.5	1000	0.50	0.1	47.0	C62V
BZV55-C68	68.00	64.00	72.00	200	2.5	1000	0.50	0.1	51.0	C68V
BZV55-C75	75.00	70.00	79.00	250	2.5	1500	0.50	0.1	56.0	C75V
BZV55-C82	82.00	77.00	87.00	300	2.5	2000	0.50	0.1	62.0	C82V
BZV55-C100	100.00	94.00	106.00	450	1.0	5000	0.10	0.1	75.0	C100V

Notes:

STANDARD VOLTAGE TOLERANCE IS ±5% AND:

SUFFIX "A" FOR ±1%

SUFFIX "B" FOR ±2%

SUFFIX "C" FOR ±5%

SUFFIX "D" FOR ±20%

